

# Introduction to CHS2

Revolutionize Energy Storage Solutions

# CONTENTS

**01** CHS2 & Solutions

**02** Selling points and competitor analysis

**03** External Interface-CH2&CB2

**04** IOT Platform

# 01 CHS2 & Solutions

# SAJ Smart PV&ESS Solution for C&I Scenarios



CH2



CB2



CHS2



eManager-C1 Pro



R6



C6



eSolar AIO3



CM1



eManager-C1 Pro

# C&I Solar Generation solution



PV Array



75-125K



AC Distribution Box



Grid

12 MPPT, 150% PV oversizing  
adapts to complex installation scenarios

MPPT 40A high current  
matching high power component

Low starting-up voltage  
wider MPPT voltage range (180-1000V)

# 1.1-CHS2 Series Introduction



**CH2-IP66**  
**CH2-29.9~63K-T4/T5/T6**  
Currently available models  
for sale: **CH2-50K-T6**



**CB2-IP55**  
**CB2-57.3~100.3-HV5**  
Currently available models  
for sale: **CB2-100.3-HV5**



**CHS2-29.9~63K-T4/T5/T6-X**  
**CHS2-50K-T6-X**  
X indicates the Battery  
Rated Capacity

## Application Scenarios

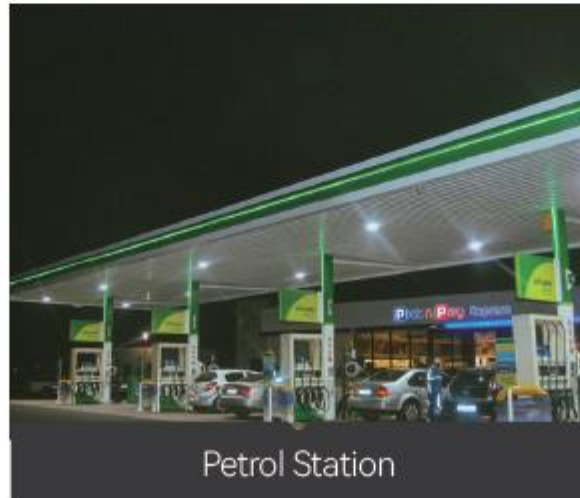

- Excellent choice for small and medium-sized business and clients with energy consumption demand
- Easy to transport and install

## 1.2-CHS2 Solutions

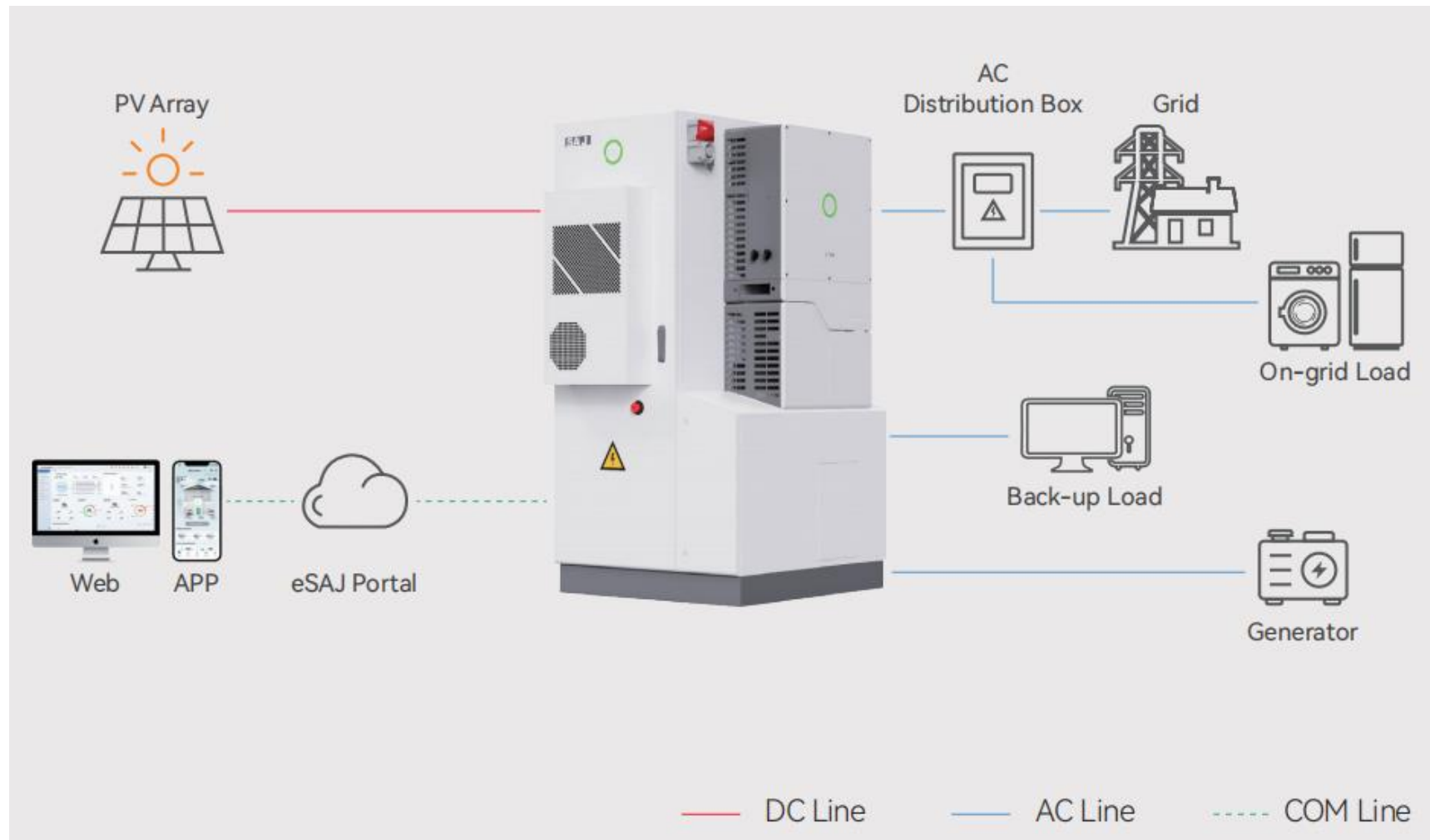

### Main application scenarios:

1. Unstable grid areas
2. High electricity prices/Large peak-to-valley price difference areas
3. Off-grid scenarios
4. Subsidized policy



# 1.3-CHS2 Solutions: AC Coupling

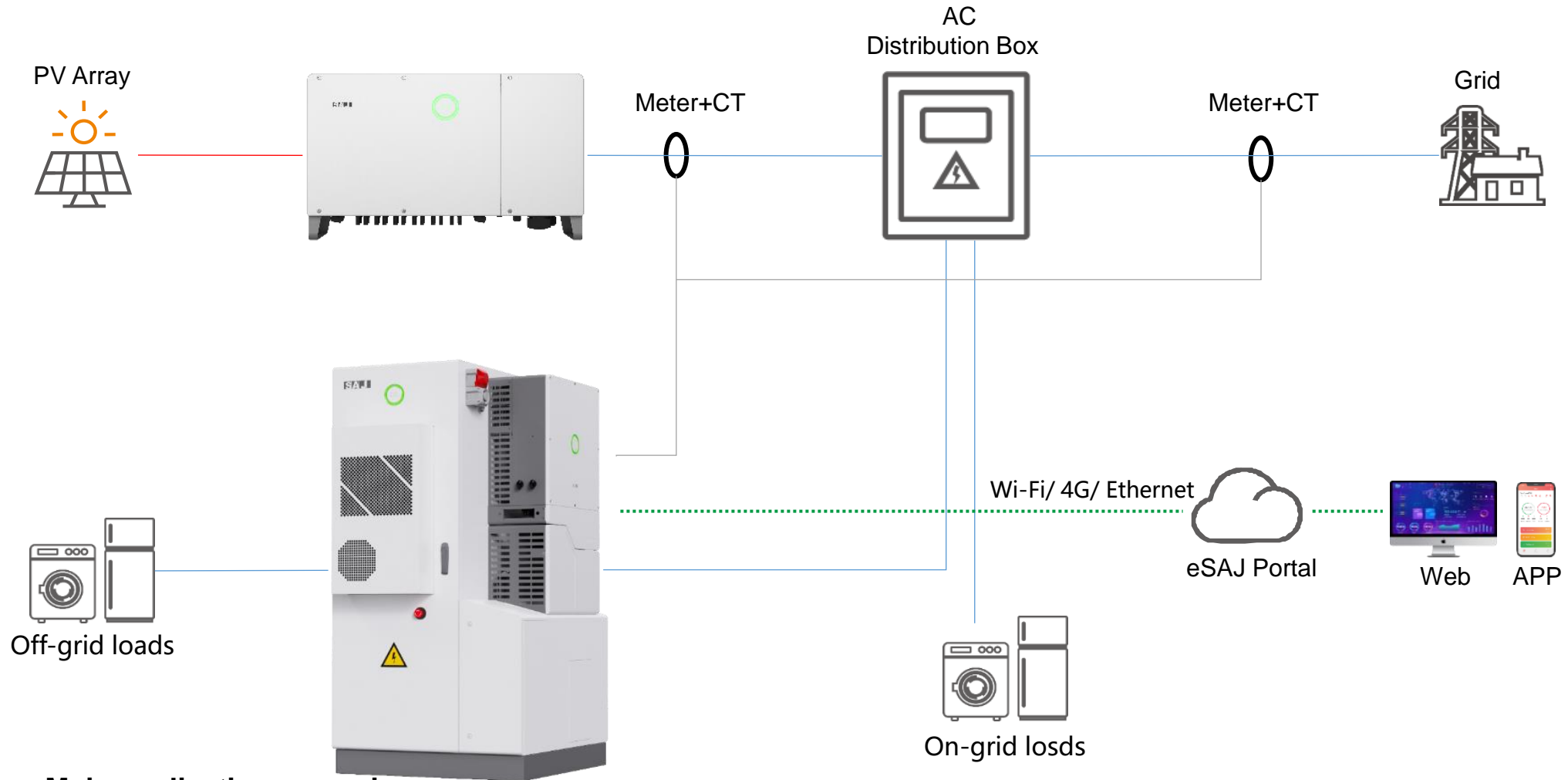

## Main application scenarios:

1. Energy storage renovation
2. Due to the site installation conditions are limited (such as DC cable is too long), PV and Energy storage need to be separate scenarios.
3. VPP Subsidized markets

# 1.4-CHS2 Solutions:On-Grid parallel

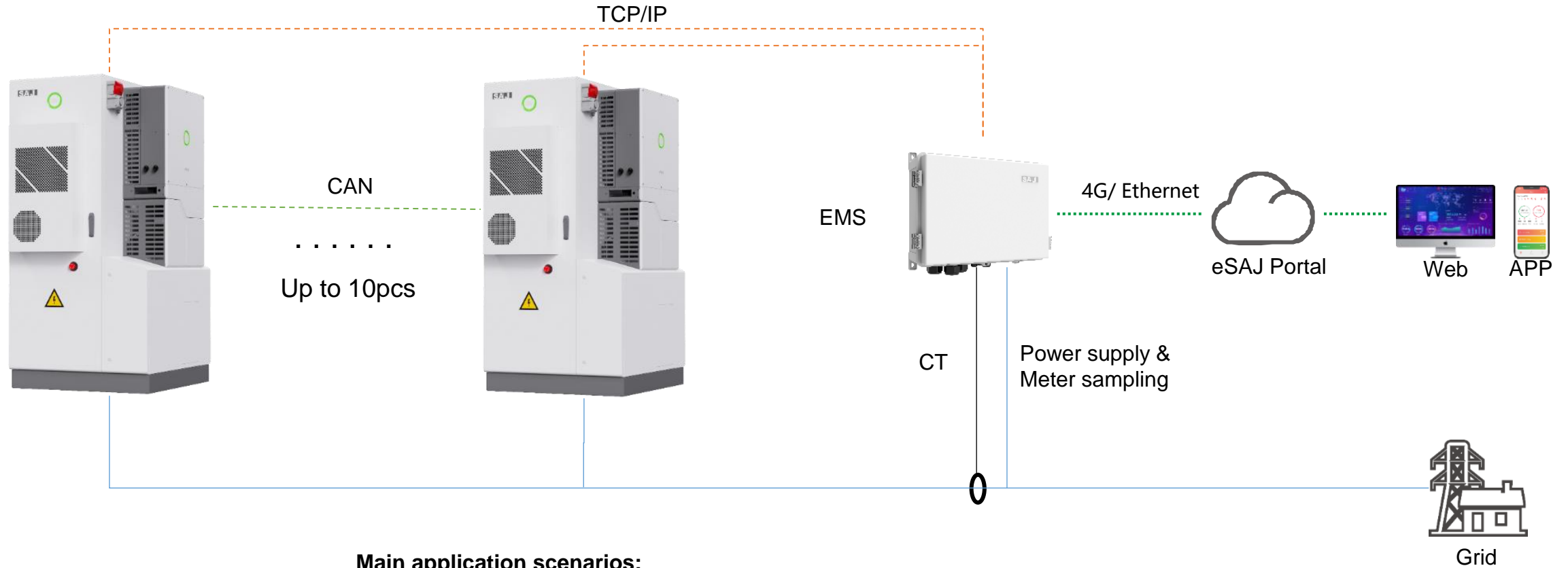

### Main application scenarios:

1. Scenarios where the power grid is relatively stable
2. Users have high load power, such as factories, farms, commercial complexes, etc

# 1.5- Battery capacity expansion

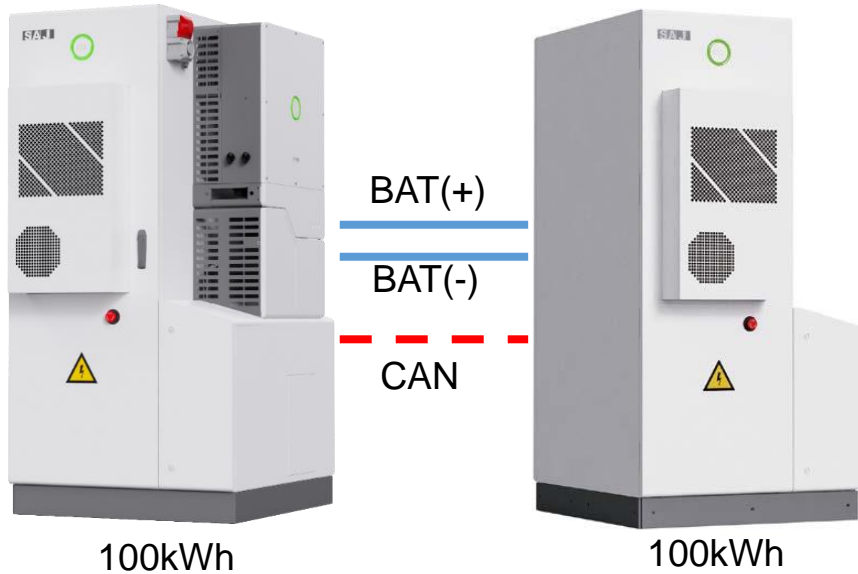

1. The power and communication cables between battery cabinets are not provided in the accessory kit;
2. The wiring terminals are configured by SAJ
3. A single CH2 supports up to 4 CB2 connections

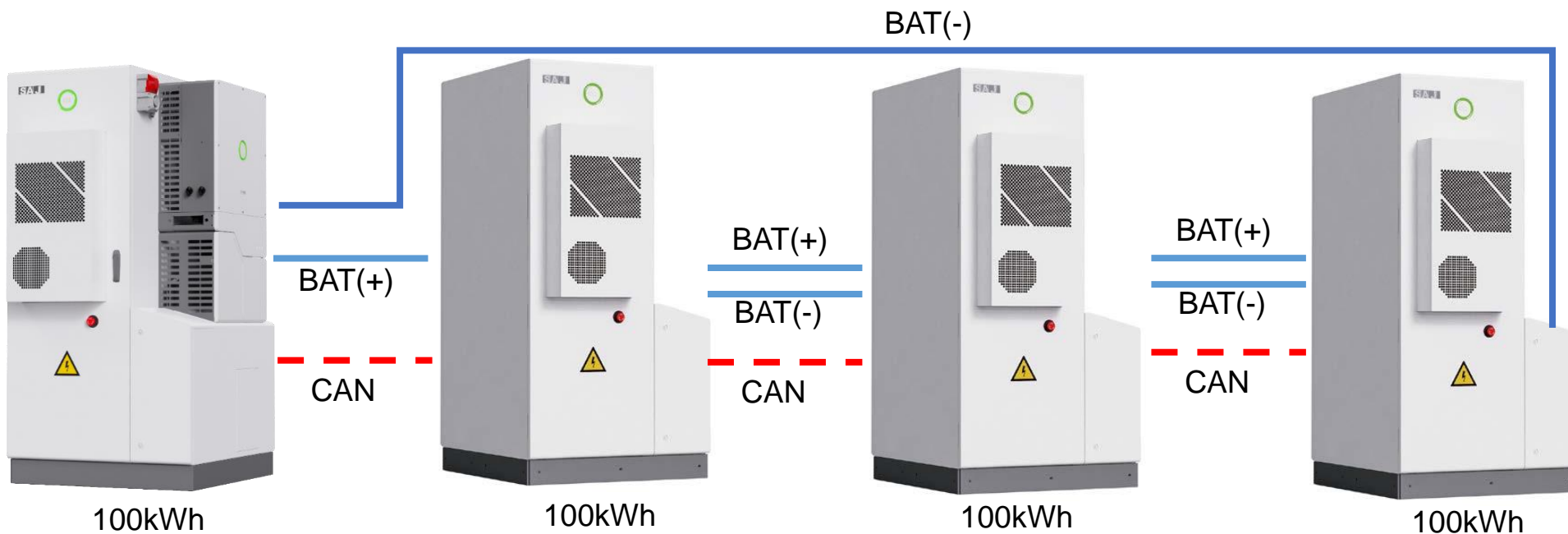

## 1.6- CHS2 Series Introduction



Sound and light alarms for firefighting



Emergency stop button



Temperature control system:  
Air conditioning



Air conditioning condensate  
water pipe

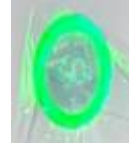

Display of status and capacity of  
the battery



Battery high-voltage control  
box

# 1.6- CHS2 Series Introduction



Smoke detector



Air conditioning cold air outlet



Aerosol, erupted at temperatures above 170 °C, extinguishing fires and preventing combustion

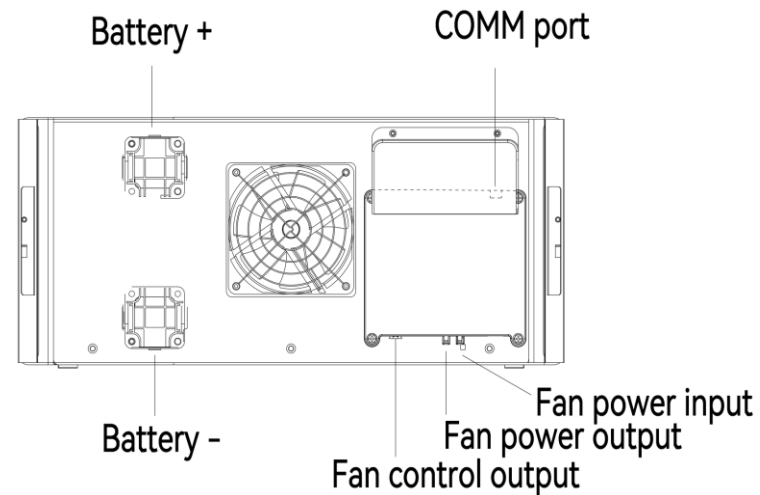

## 1.6- CHS2 Series Introduction



Communication adapter board



Temperature and humidity sensor



Water immersion sensor



Water immersion sensor

## EMS Gateway: Intelligent Communication Box

### Smart communication box

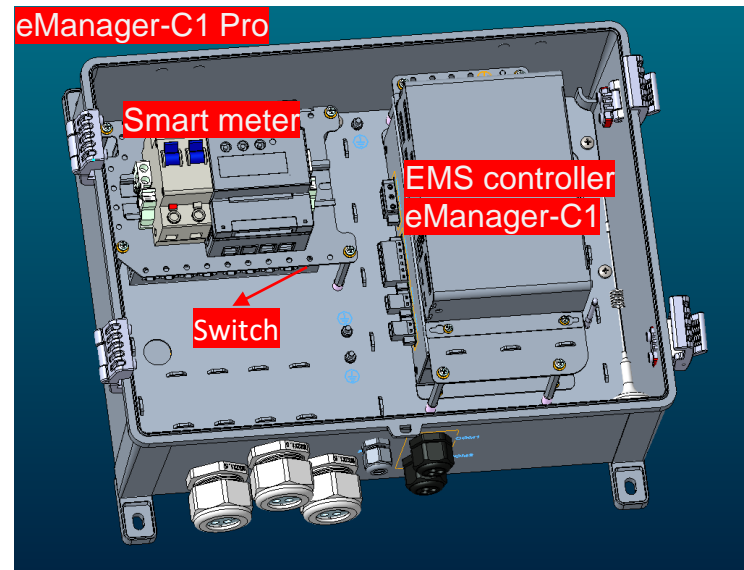

#### Product Features:

- Integrating EMS controller, ethernet switch, and smart meter
- Bluetooth/4G/Ethernet/RS485, Connection diversified
- Up to 10 inverters communication and monitoring
- Local near-end + remote/mobile all-weather monitoring, 7\*24 real-time monitoring without restrictions
- Cloud-side collaboration to achieve remote Operation
- Support remote Web/APP access in various forms for power station maintenance, simplify operation and maintenance, and optimize operating costs
- Compact design, IP65 protection

# 02 Selling points and Competitor analysis



## 2.1-CH2-PV Input

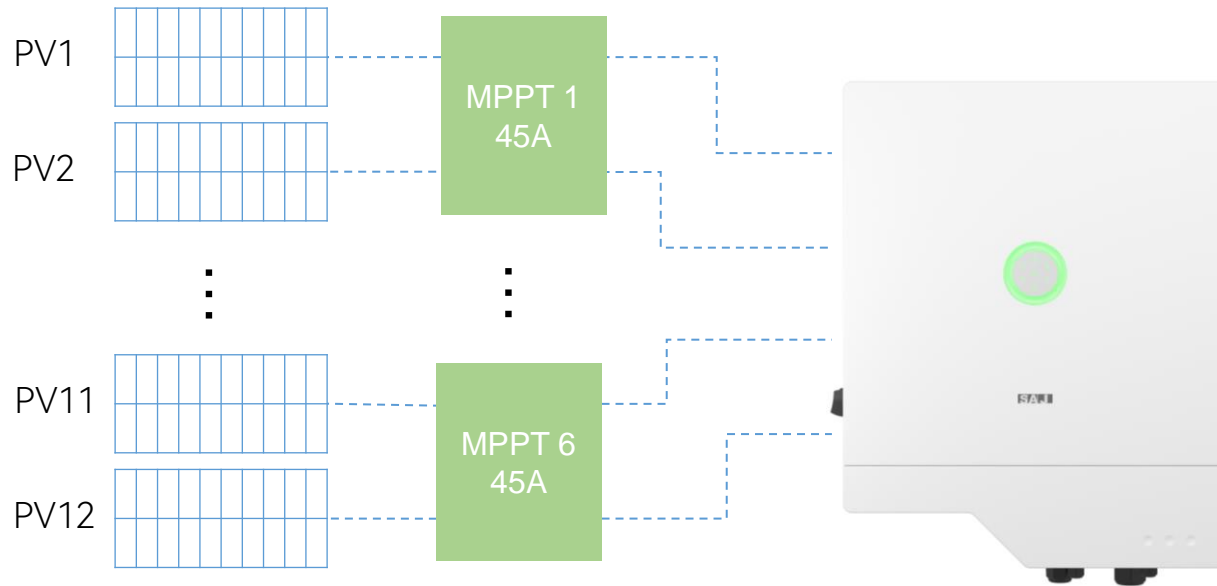

- **Max 22.5A input current, match high power (210) PV panel.**
- **Up to 6MPPTs, 200% PV oversizing.** When the PV power is supplied to the inverter for full power operation, the battery is also charged. Maximize energy utilization.

Brand	Deye	Solis	KSTAR	SOLINTEG	AISWEI	ATESS	SAJ
MPPT Quantity	4	4	3	4	6	3	6
Maximum string current [A]	18A	20A	18A	15A	18A	20A	22.5A

## 2.2-CH2-200% PV oversizing

SAJ

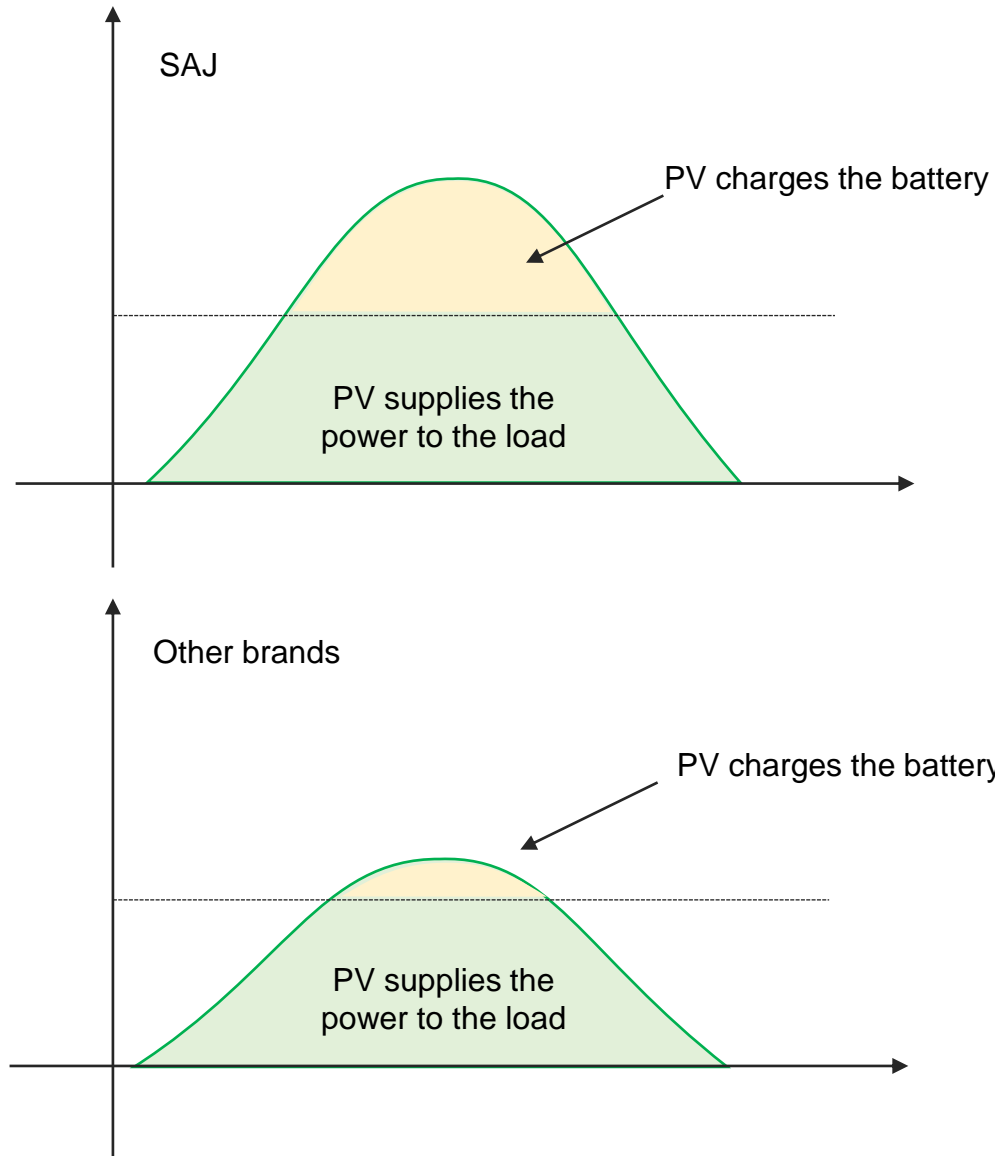

The Photovoltaic Storage System can store excess energy into the battery through the PV oversizing, providing power to the load in case of power outage or insufficient sunlight.

**Slightly high of the initial investment in PV panels.**

The optimal investment ratio depends on factors such as the project's geographical location, design details, and electricity costs.

**Much More Energy Yield \* in 10 years**

**ROI(Return on investment) Significantly improved**

Maximize energy self consumption.

**25% cost per kWh reduced**

\*Simulated calculation parameters:

1. location is in Johannesburg,SA
2. Panel cost: 0.15\$/W
3. This calculation does not include efficiency attenuation, and the results are for reference only

## 2.3-CH2-25% LCOE reduce and 32% higher revenue



The initial investment of the SAJ solution is **14.25%** more than that of the other solution.

The power generation in ten years can increase by **54%**, and LCOE (Levelized Cost of Energy) can be reduced by **25%** in ten years.

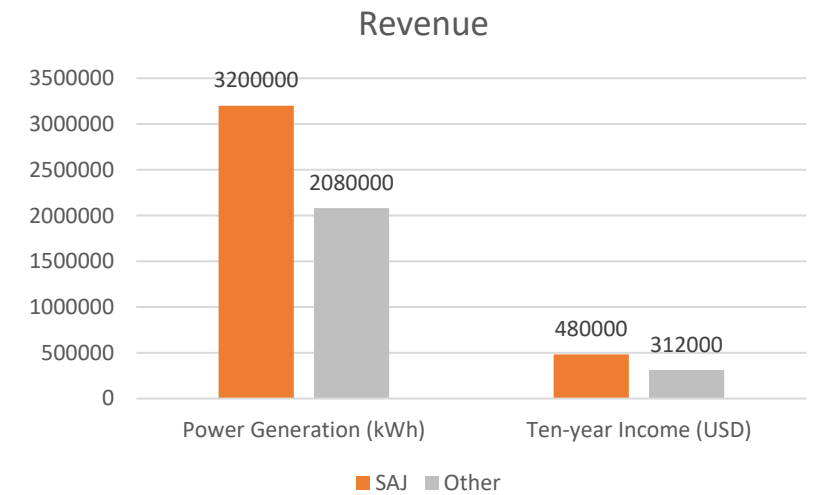
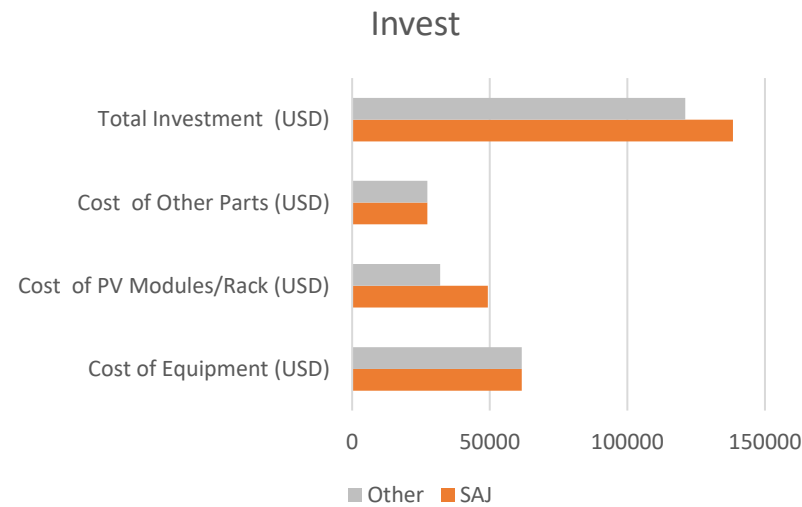
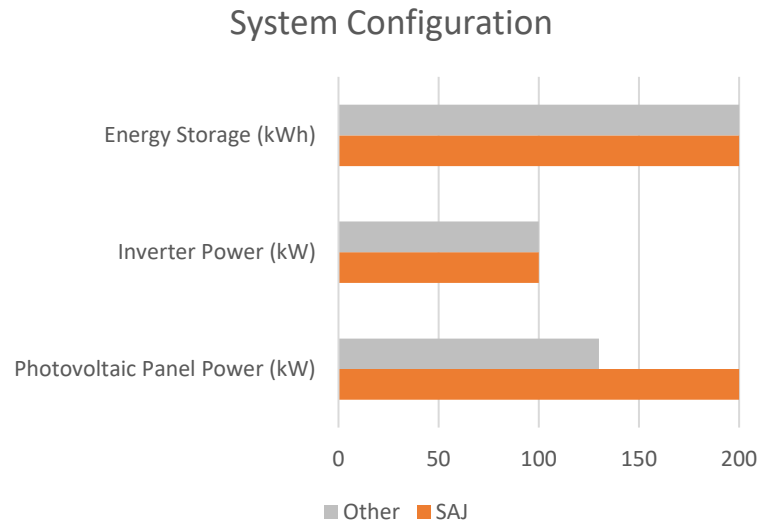

## 2.5-CH2-AFCI Standard configuration

SAJ

The SAJ inverter comes standard with AFCI, making safety a basic configuration.



- An Standard configuration AFCI module adopts a high-precision current sensor to collect the string current.
- The frequency spectrum of the sampled current is analyzed through the dc arcing detection algorithm to accurately detect the arcing position, quickly turn off the inverter, and send an alarm.
- Minimize the damage of the power plant caused by dc arcing and improve its safety.
- Complies with UL 1699B-2018 standard and IEC63027 (Draft).

Other brands, such as Deye's AFCI, are optional function that require additional costs. The safety has not guaranteed.

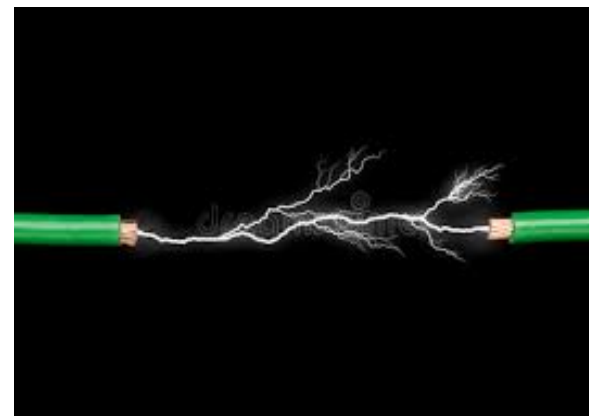

Protection

Integrated

Anti-islanding Protection, PV String Input Reverse Polarity Protection, Insulation Resistor Detection, Residual Current Monitoring Unit, Output Over Current Protection, Output Shorted Protection, Surge Protection, **Arc Fault Circuit Interruption (AFCI optional)**

## 2.6-CH2-AC side Selling points



### AC Overload capacity

AC Overload capacity is an important indicator of the inverter's output capability, with obvious advantages in off-grid scenarios.

Brand	Deye	Solis	KSTAR	SOLINTEG	AISWEI	ATESS	SAJ
Power	50kW	50kW	50kW	50kW	50kW	50kW	50kW
Continuous overload capacity	1.1	1.1	1.1	1.1	1.1	1.0	1.1
Short time overload capacity	1.5	1.5	/	1.2	/	1.2	1.5

### AC Surge Protection

III General nominal discharge current 6KA,II General nominal discharge current10kA.

Three levels of Surge Protection: the inverter is at risk of short-circuiting when struck by a surge, usually without a feedback signal.

Two levels of Surge Protection: the inverter is open-circuit when struck by a surge and has a feedback signal.

Brand	Deye	Solis	KSTAR	SOLINTEG	AISWEI	ATESS	SAJ
AC SPD	III	II	III	/	/	II	II

SAJ's inverter has a stronger surge protection capability.



## 4 °C temperature difference between battery cells

### Operating Temperature Range: -30°C-50°C

The smaller the temperature difference between battery cells, the better the consistency of the battery system's long-term operation, the longer its lifespan, and the stronger its performance.

Cell temperature difference

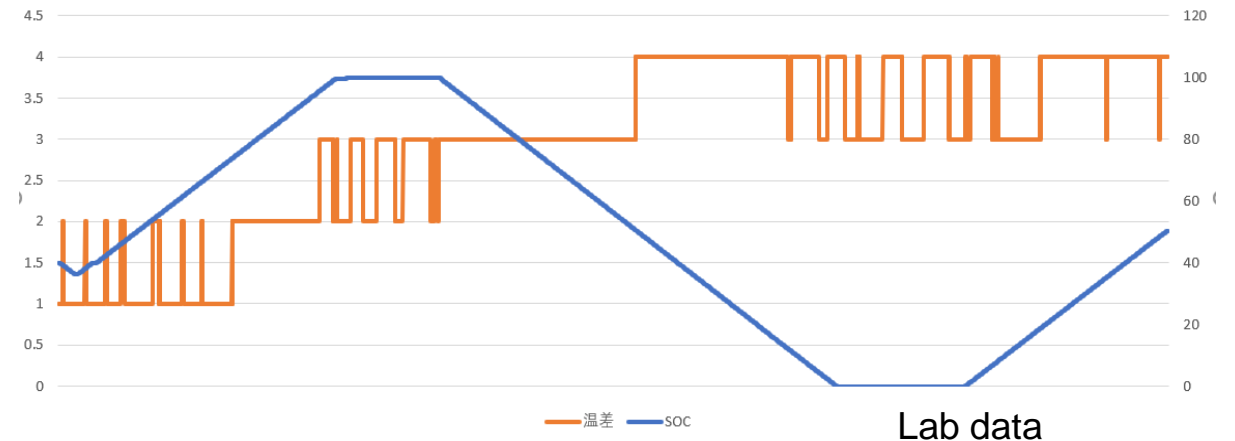

# 2.8-CB2-30% more cycles with 280Ah battery cells



## 280Ah High-performance batteries for long lifespan

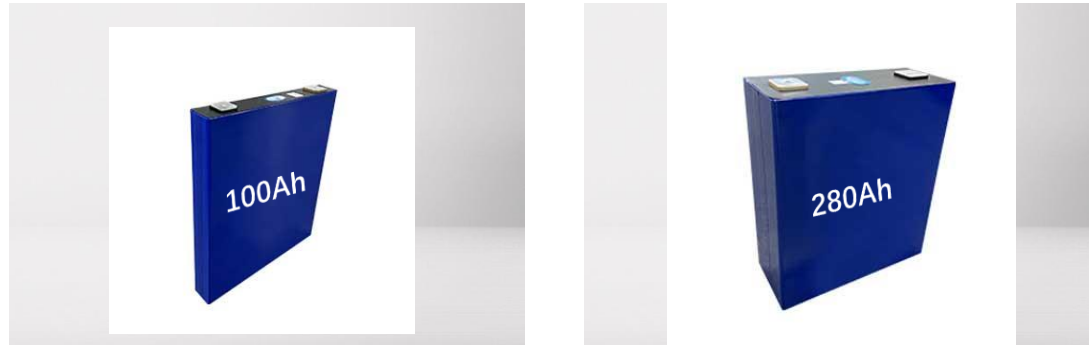

Other solution

- 6000+ times cycle life

SAJ solution

- 8000+ times cycle life

	Max. Charging/ Discharging Current	Charging/ Discharging C-ratel
SAJ	150A	0.5C
Other	100A	0.35C

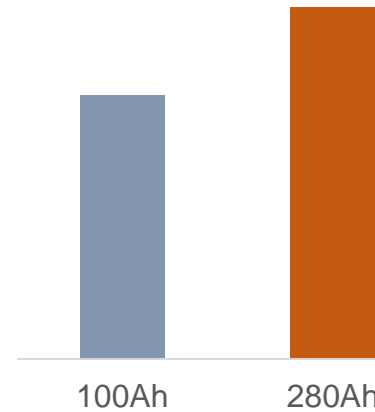

### 30%+ More Cycles

The energy density is higher  
More cycle life and higher power  
throughput

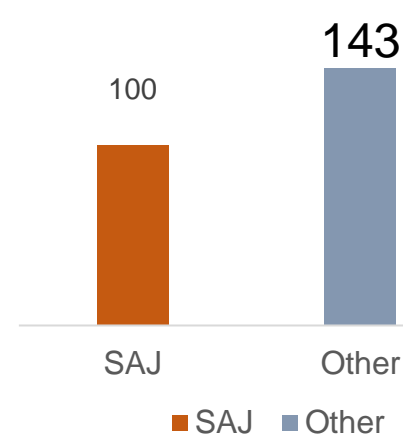

### 30% Less battery configuration

For 50kW AC output, The initial  
investment of the SAJ solution is lower  
than that of other solution

# 2.9-CB2-Battery System Selling points

6 levels of active/passive fire protection to ensure the safety of customer's property.

**1**  
Core-level voltage sampling

3.225 V, 3.112 V, 3.216 V  
3.222 V, 3.221 V, 3.215 V  
3.215 V, 3.212 V, 3.210 V

**2**  
Core-level temperature sampling

30.5°C, 29.1°C, 27.8°C  
73°C, 37.3°C, 29.4°C  
31.1°C, 28.5°C, 26.6°C

**3**  
High Precision Sensors

- CO Sensor
- Smoke Sensor
- Temperature and humidity sensors
- Flood sensors

**4**  
safety valve

**5**  
Fire-fighting

- Audible and visual alarms
- Aerosol

**6**  
Electrical safety

- Positive and negative dual redundant contactors
- Release switch



## 2.10-CHS2-Save 60% of installation time



### Installation

Pre-wiring to all components, minimize installation labor costs.

### Requirement Space

Compact structural design, flexible installation, and maximum utilization of on-site space.

### System

Battery system DC coupling reduces conversion losses and improves efficiency.

# 3-1 External Interface -CHS2

---

## 3.1-External Interface-CH2-12V Power Output(RSD)

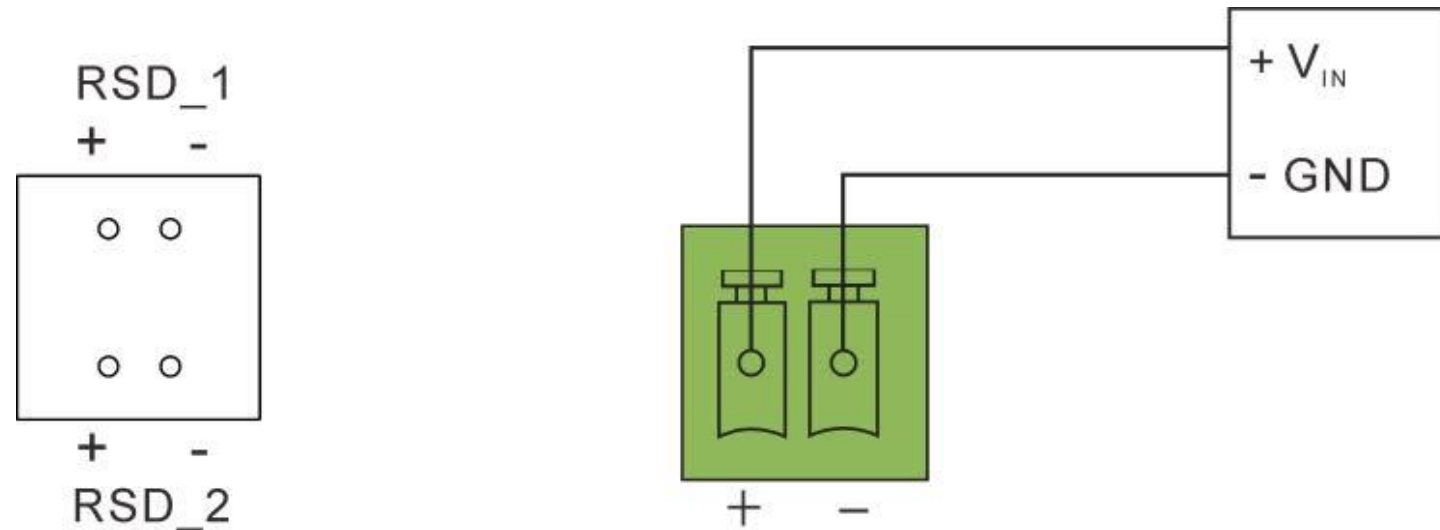

Note:

- 1、 RSD\_1, RSD\_1 supplies power to the external photovoltaic fast shutdown module, and controls the power on and off by controlling the power of the module.
- 2、 Reserve two 12V/1A interfaces.

## 3.2-External Interface-CH2-12V Power Output(RSD)

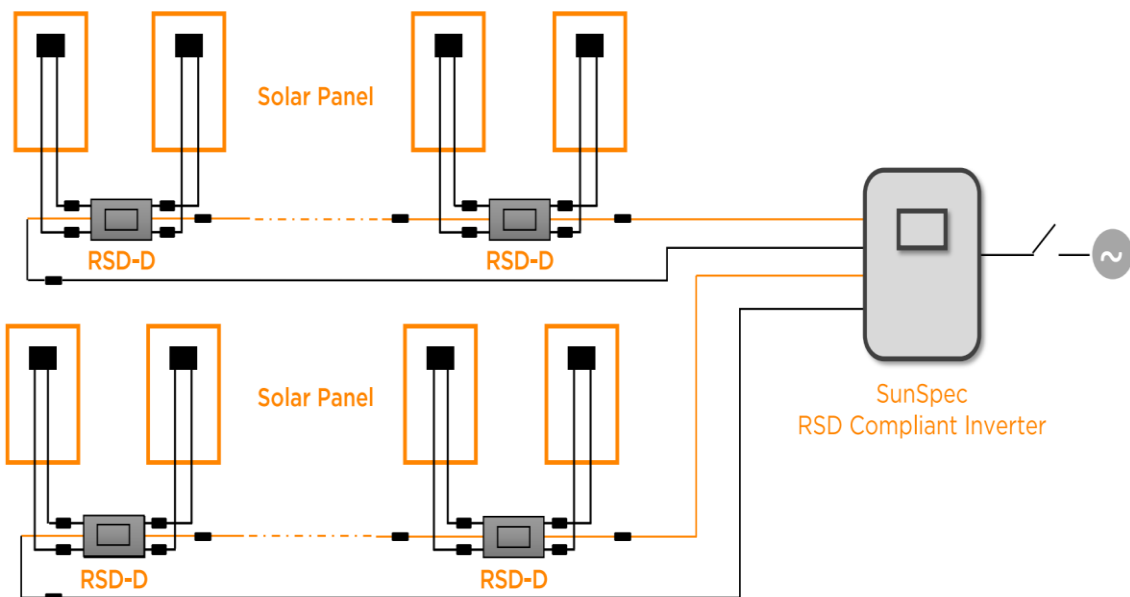

Note:  
In SunSpec RSD Compliant Inverters system, only RSD Devices(RSD-S-PLC& RSD-D) are needed for the modules to realize module-level rapid shutdown function.

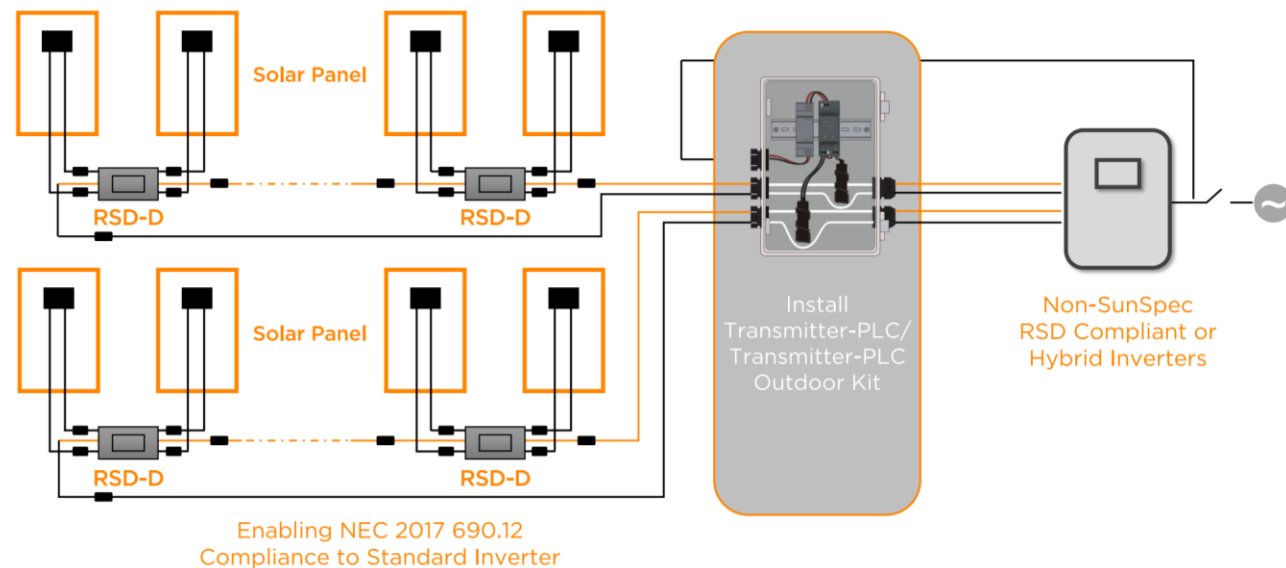

Note:  
In Non SunSpec RSD Compliant & Hybrid Inverters system, a Transmitter device (Transmitter-PLC / Transmitter-PLC Outdoor Kit) needs to be installed together with RSD Devices (RSD-S-PLC& RSD-D) to realize module-level rapid shutdown function.

### 3.3-External Interface-CH2-Emergency Stop Dry Contact

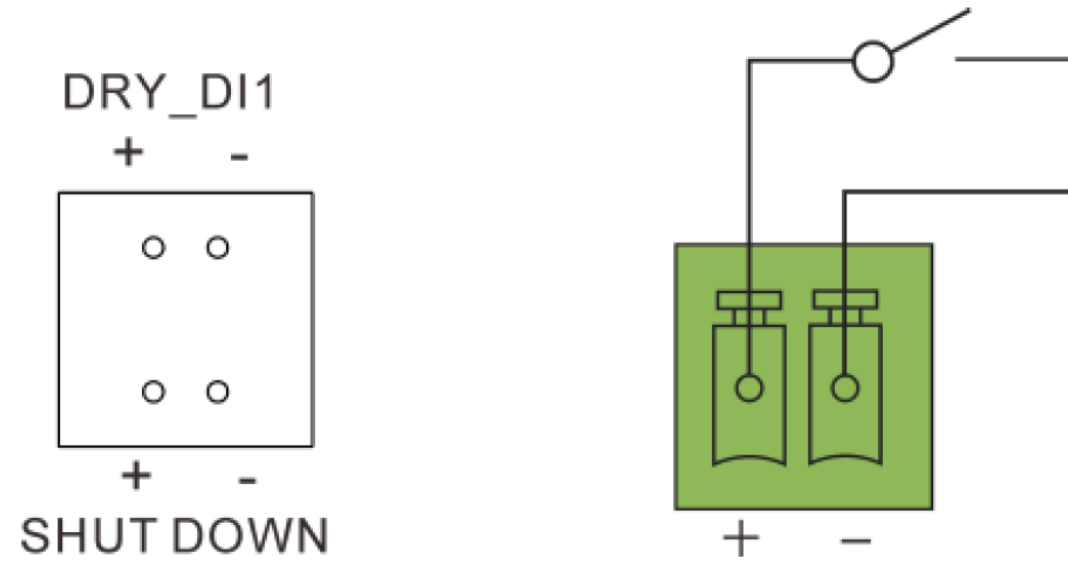

When + contact and - contact are shorted by external controlled switch, the inverter will stop immediately.

DRY\_DI1: Reserved input dry contact.

# 3.4-External Interface-CH2-Generator control signal

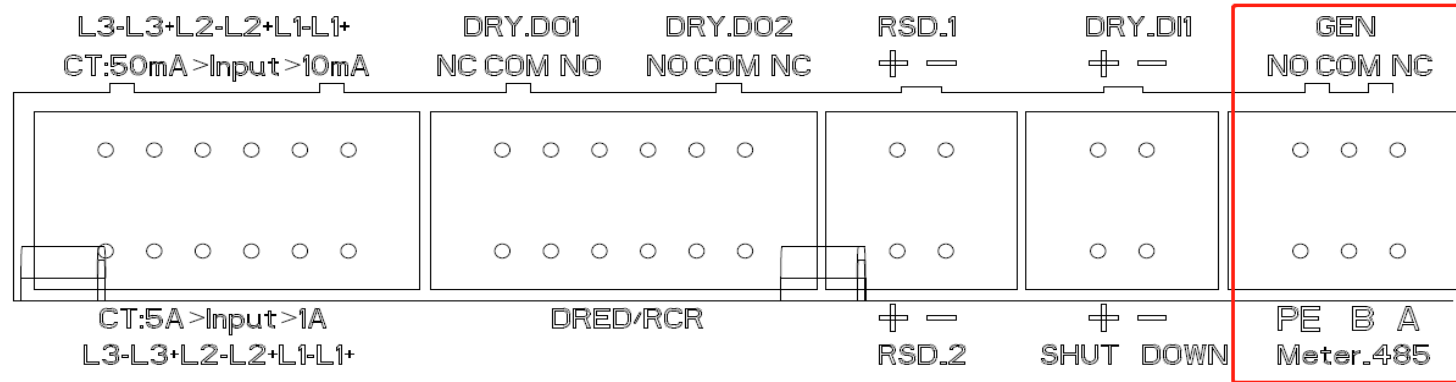

Generator start/stop interface to control the generator start and shutdown.

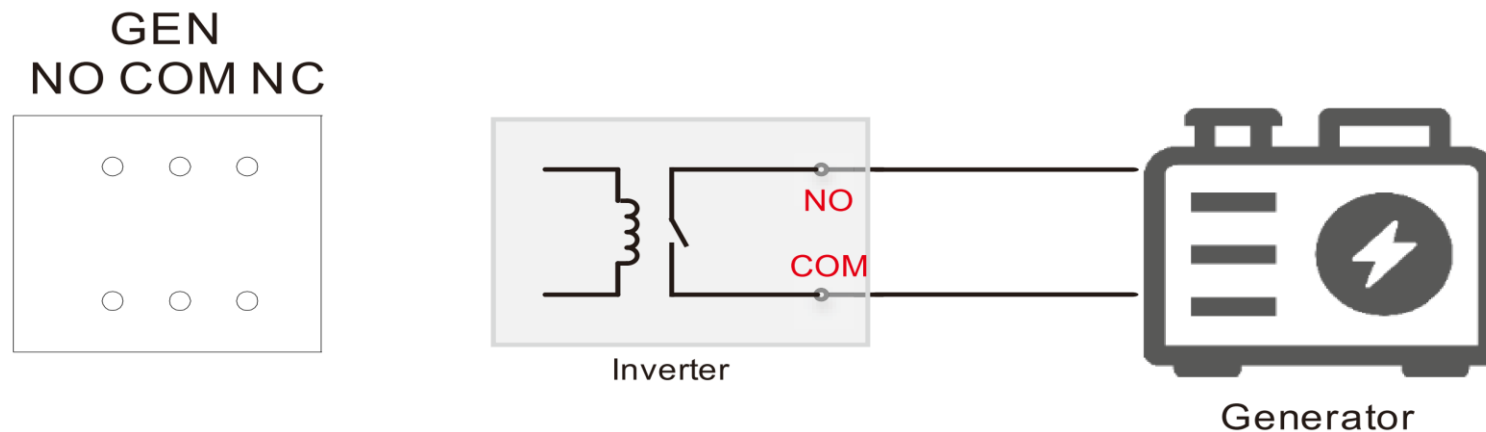

# 3-2 External & Internal Interface -CB2

## 3.16-External Interface-CB2 (IP55) -Emergency stop button

SAJ

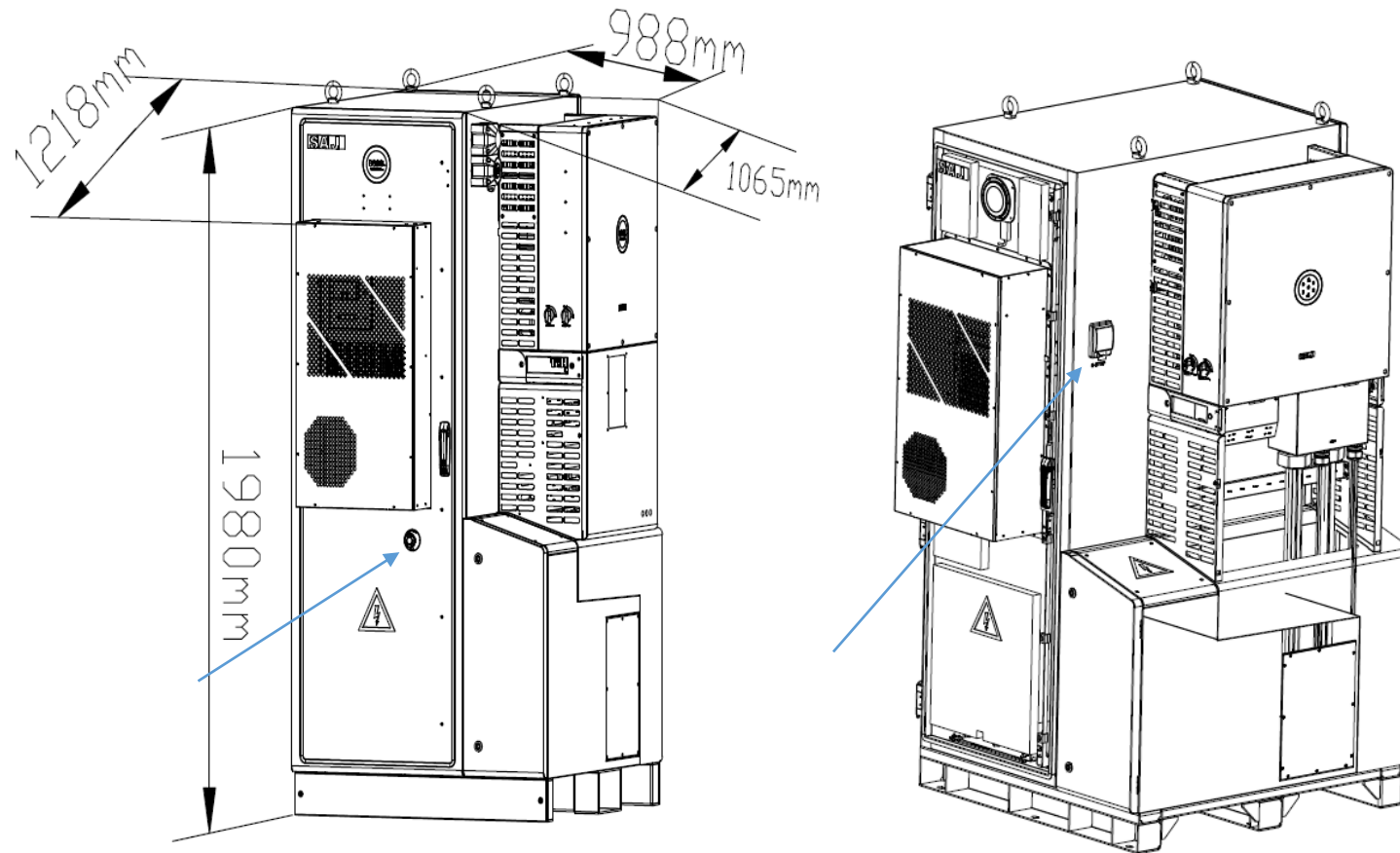

**Emergency stop button:** Both the inverter and battery will shut down.



# 3.17-External Interface-CB2(IP55)-High voltage control box

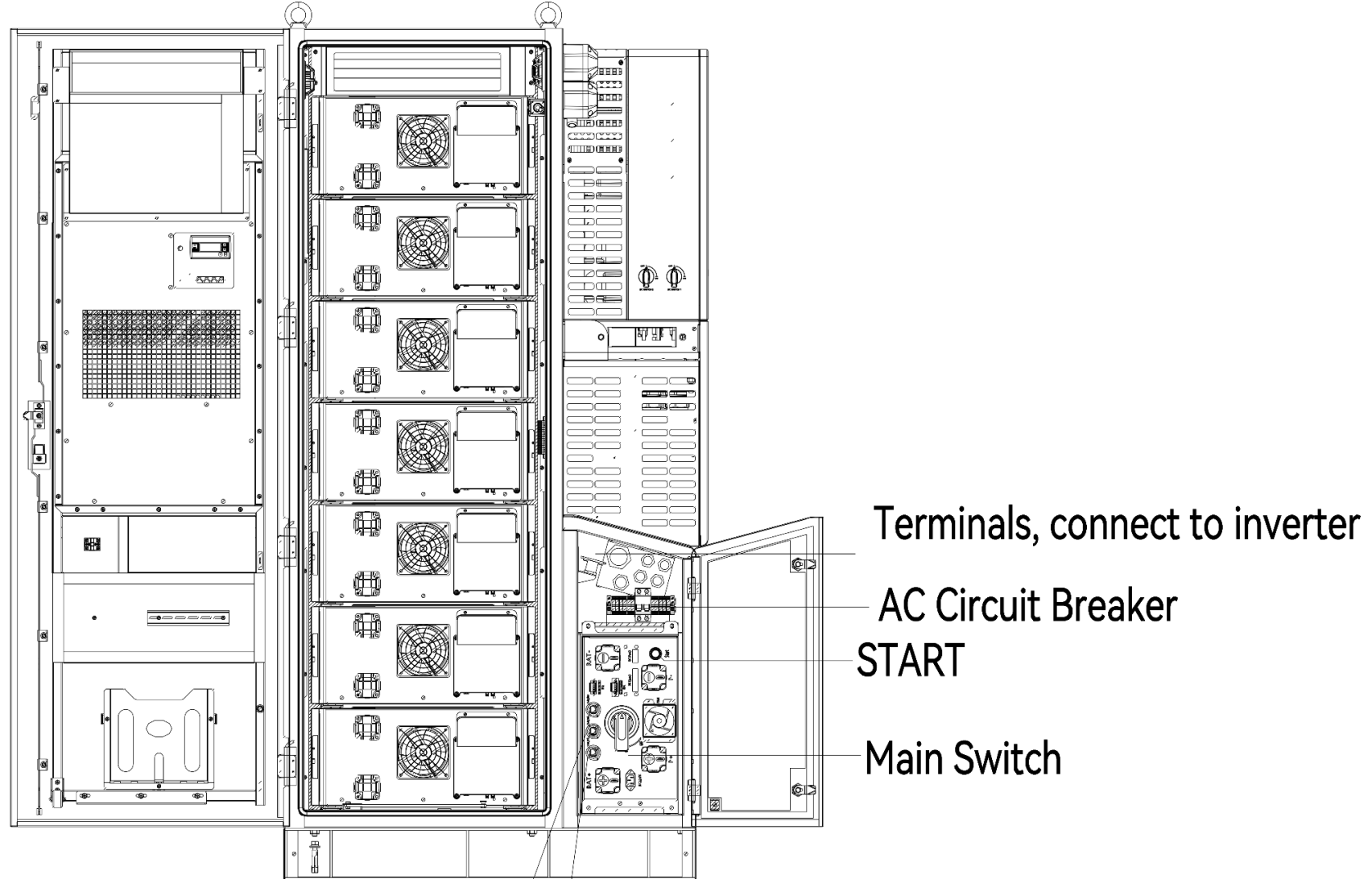

COM\_PCS, connect to inverter BMS\_1 port  
COM\_PAR, to expand battery system

## 3.18-External Interface-CB2(IP55)-High voltage control box

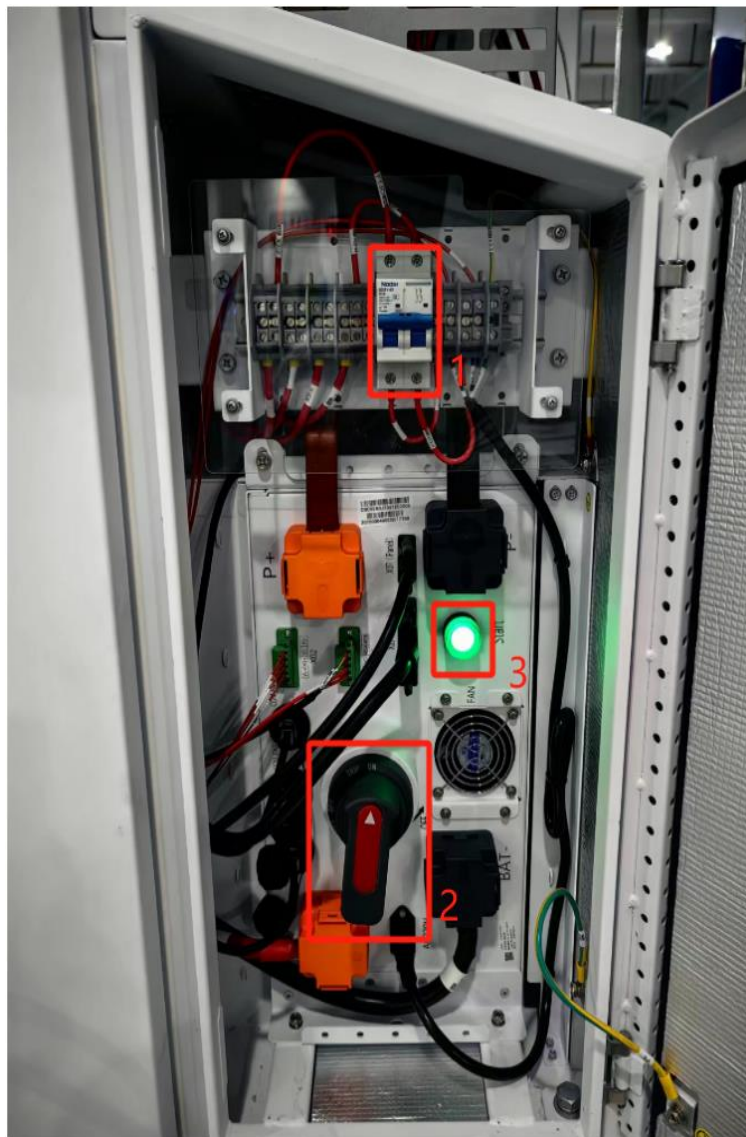

### High voltage control box:

- 1: AC input control switch  
(Power the air conditioner/AC-DC power supply)
- 2: DC circuit breaker  
(manual opening/resetting of main circuit power supply);
- 3: Start/power-off contact button switch  
(Automatic reset, With green indicator light, start (light on) and stop (light off), Press the button for 4-5 seconds to take effect.)

### Startup steps:

1. Connect the system and enable the 1(AC input control switch).
2. Rotate the 2(DC circuit breaker) to ON.
3. Press the 3(contact button switch), press the button for 2-3 seconds to start.
4. BMS automatically powers on and detects program operation.
5. The system will start running after detecting no faults.

### Shutdown steps:

1. Press the 3(contact button switch) until the switch light goes out.
2. Rotate the 2(DC circuit breaker) to OFF.
3. Turn off the 1(AC input control switch).
4. After completing the above steps, the entire machine will stop running.

# 04 IOT Platform

---

# RealTime Monitoring-WEB



Plants

Devices

Alarms

Environment

Consumption

Other Data

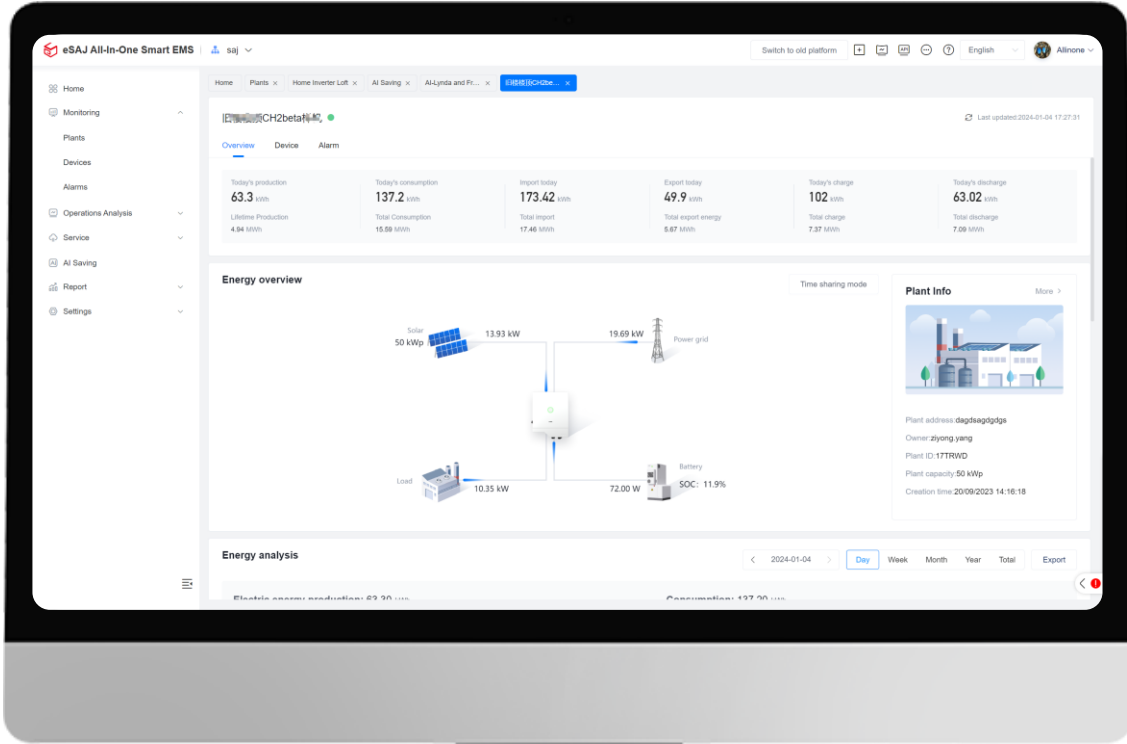
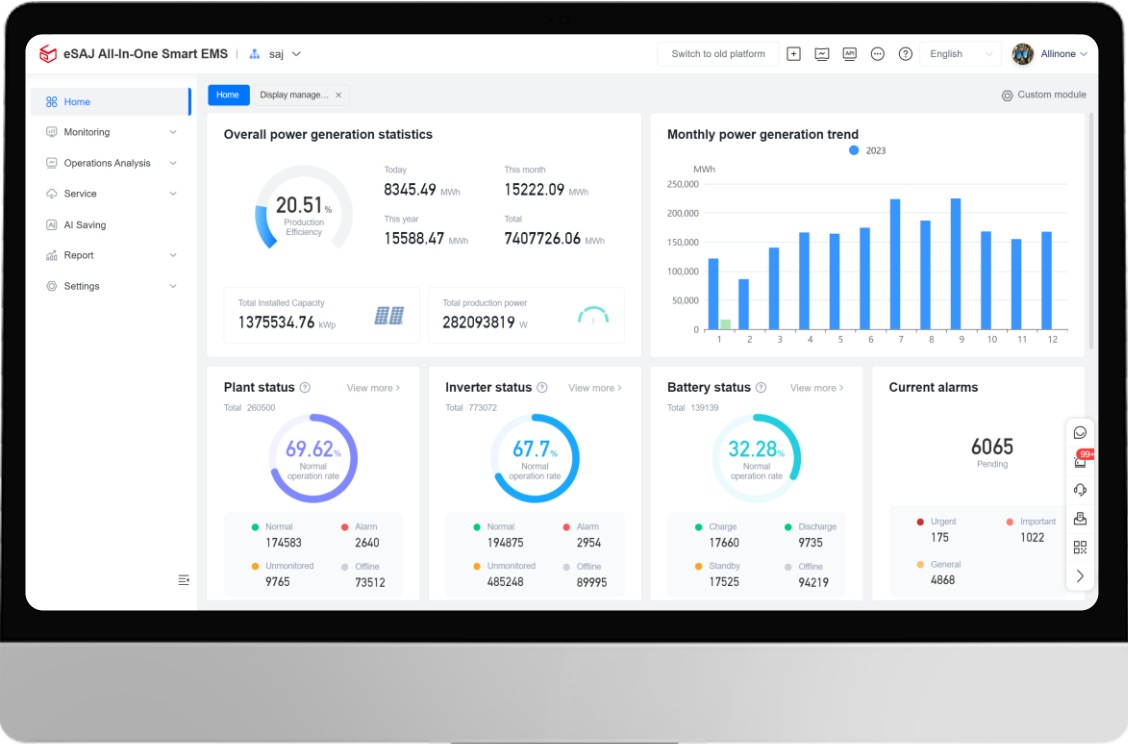

## All-round Management of Multiple Plants - Plants, Inverters, Batteries

Plants

Devices

Alarms

Environment

Consumption

Other Data

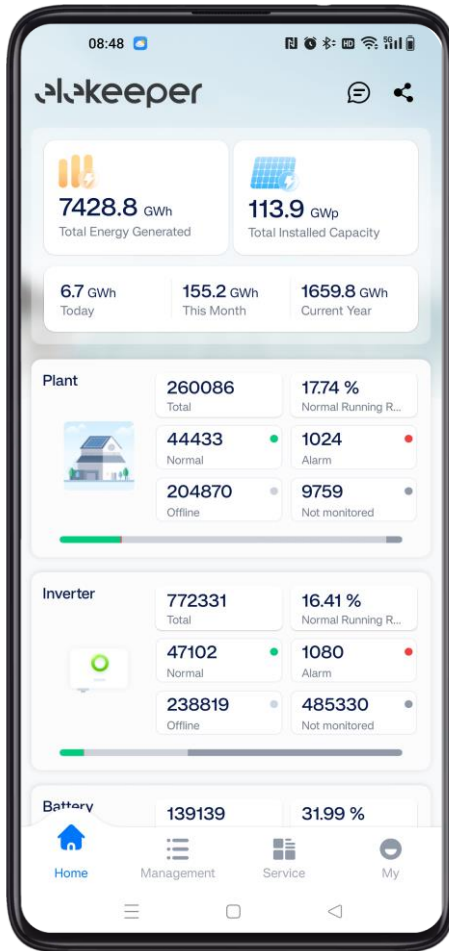

Overview

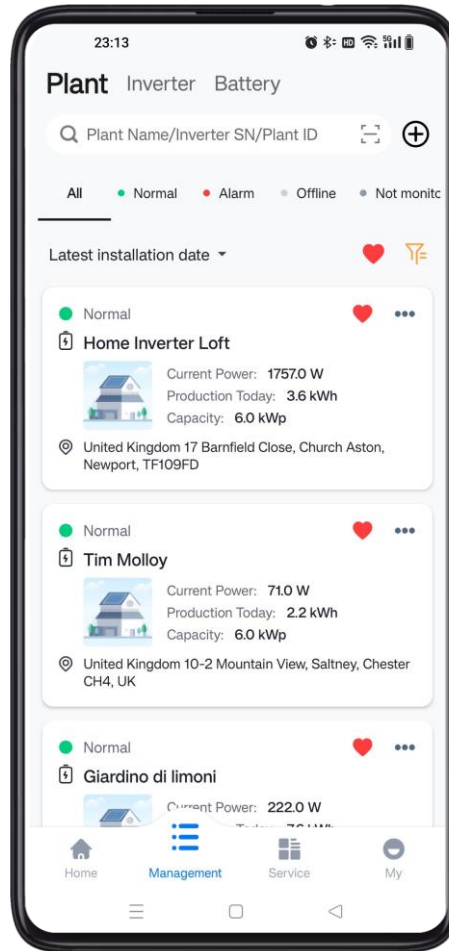

Plant Management

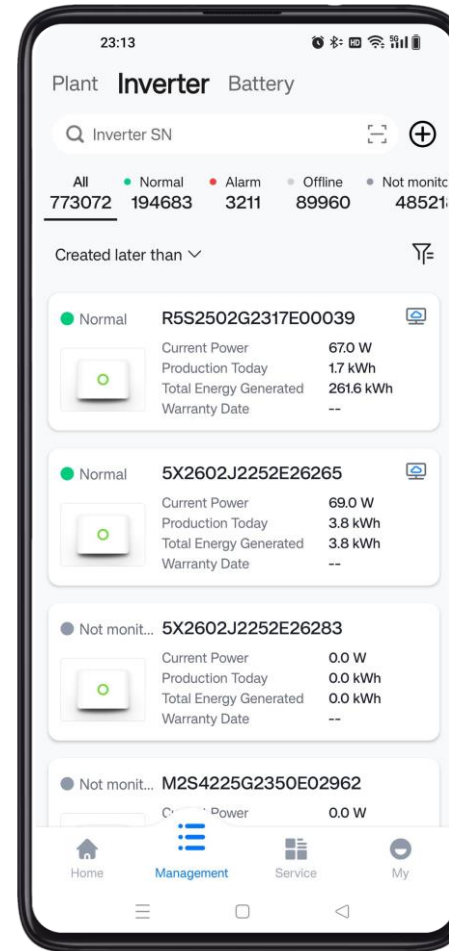

Inverter management

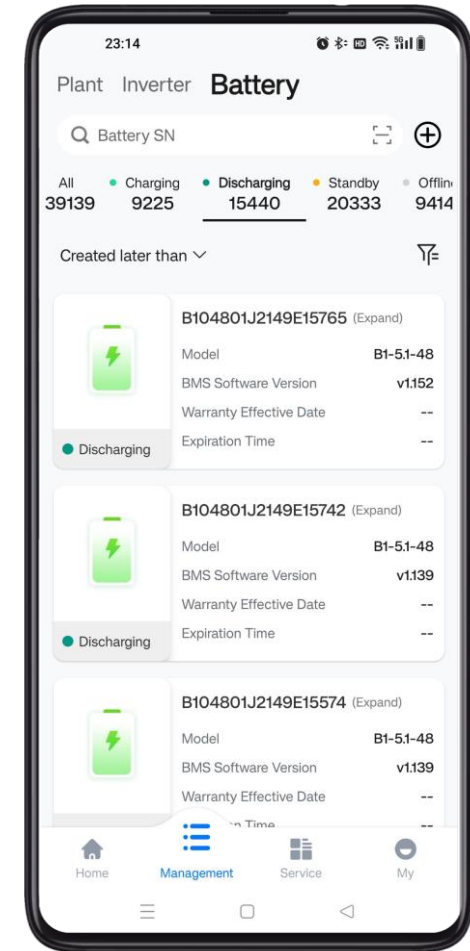

Battery management

## All-round Management of Multiple Plants - Plants, Inverters, Batteries

Plants

Devices

Alarms

Environment

Consumption

Other Data

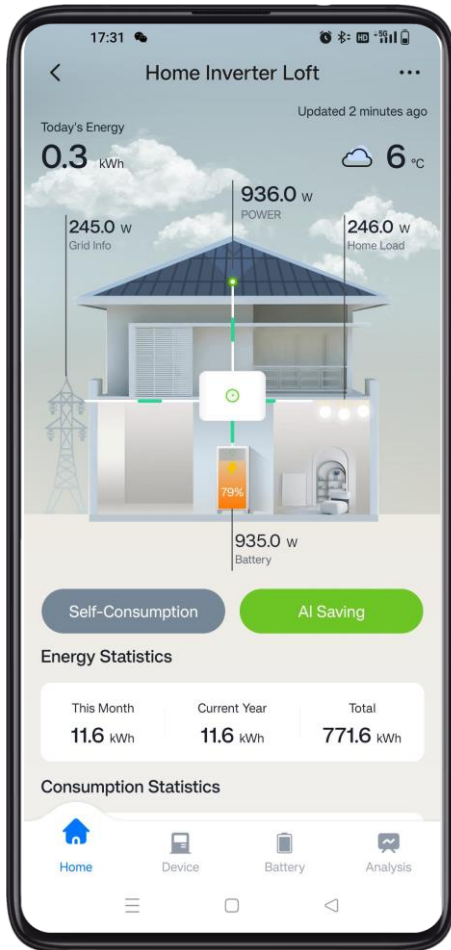

Home

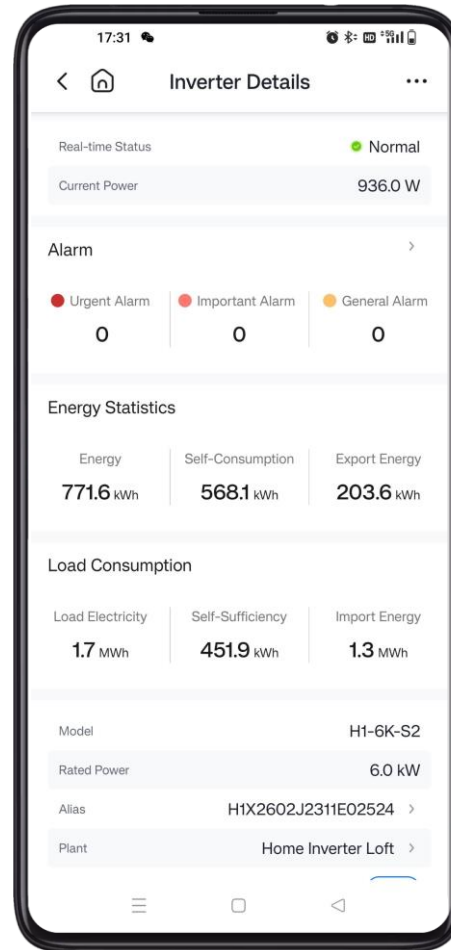

Device

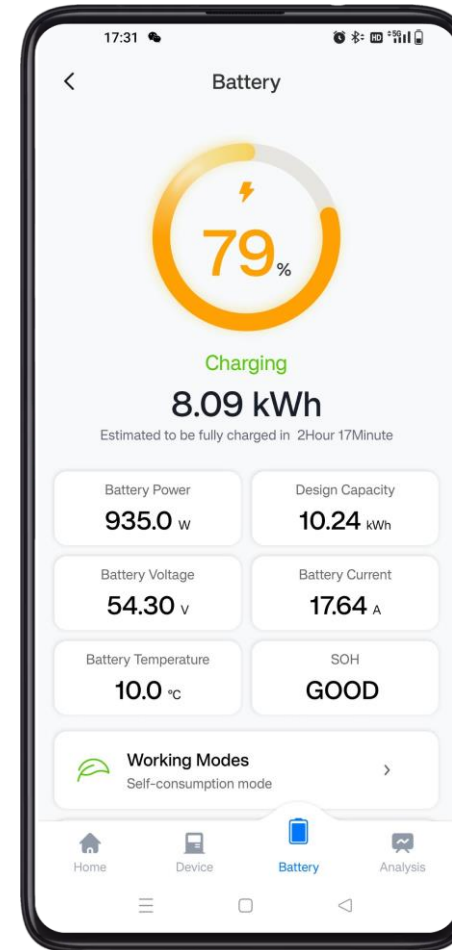

Battery

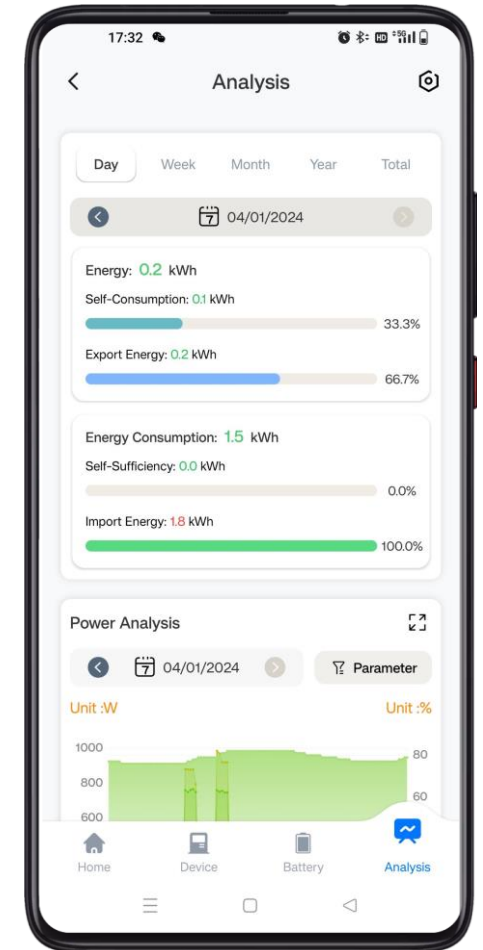

Analysis

# Energy Efficiency Management

Energy Statistics

YoY Analysis

Contrast Analysis

Power Monitoring

Home 🏠 📶 🔌 🌡️ 🔍 🔔 🔄 Last updated: 2024-01-04 08:44:21

Overview **Device** Alarm

Today's production <b>0 kWh</b> Lifetime Production 771.36 kWh	Today's consumption <b>1.4 kWh</b> Total Consumption 1.72 MWh	Import today <b>1.64 kWh</b> Total Import 1.26 MWh	Export today <b>0.16 kWh</b> Total export energy 203.56 kWh	Today's charge <b>0.72 kWh</b> Total charge 552.42 kWh	Today's discharge <b>0.59 kWh</b> Total discharge 436.54 kWh
---	--	---	--	---	---

### Energy overview

Self-consumption mode

#### Plant Info

Plant: 17 Barnfield Lane, Church Aston, address: Newport, NP23 5FD  
 Owner: [Redacted]  
 Plant ID: 30[Redacted]  
 Plant capacity: 6 kWp  
 Creation time: 24/10/2023 23:39:15

### Energy analysis

2024-01-03 Day Week Month Year Total Export

Electric energy production: 4.00 kWh  
 Consumption: 4.00 kWh

2.47 kWh (Self-Consumption) | 1.50 kWh (Export) | 3.50 kWh (Import)

Self-Sufficiency rate: 12.60% (0.50 kWh)

### Energy analysis

2023-12-29 T 2024-01-04 Day **Week** Month Year Total Export

Electric energy production: 22.00 kWh  
 Consumption: 25.90 kWh

12.58 kWh (Self-Consumption) | 9.40 kWh (Export) | 25.00 kWh (Import)

Self-Sufficiency rate: 3.20% (0.84 kWh)

### Energy analysis

2023-12 Day Week **Month** Year Total Export

Electric energy production: 210.00 kWh  
 Consumption: 771.50 kWh

170.23 kWh (Self-Consumption) | 39.80 kWh (Export) | 640.60 kWh (Import)

Self-Sufficiency rate: 17.00% (130.85 kWh)

### Plant weather

Today 04/01 08:53:40 Cloudy 6°C

Today	Tomorrow	Saturday	Sunday	Monday
04/01	05/01	06/01	07/01	08/01
6°C	4°C	4°C	0°C	0°C

### Social contribution

	CO2 Emission reduction t	Trees planted m³	Standard coal saved t
This Year	0.01	0.02	0
Total	0.77	1.37	0.31

# Energy Revenues and Cost Management



## Cost Overview

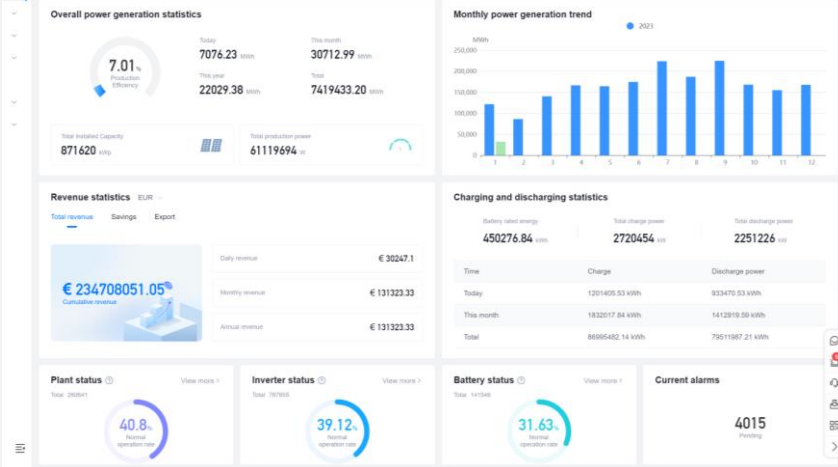

## PV Revenues



## Energy Storage Revenues



## Daily Cost



日期	合计	尖	峰	平	谷	
2023-07-31	312.03 kWh ¥236.01	¥236.01	10.03 kWh ¥31.01	22.03 kWh ¥31.01	22.03 kWh ¥36.61	10.03 kWh ¥31.01
2023-07-30	112.03 kWh ¥345.01	¥345.01	12.03 kWh ¥35.01	24.45 kWh ¥35.01	24.45 kWh ¥35.91	12.03 kWh ¥35.01
2023-07-29	312.03 kWh ¥236.01	¥236.01	10.03 kWh ¥31.01	22.03 kWh ¥31.01	22.03 kWh ¥36.61	10.03 kWh ¥31.01
2023-07-28	112.03 kWh ¥345.01	¥345.01	12.03 kWh ¥35.01	24.45 kWh ¥35.01	24.45 kWh ¥35.91	12.03 kWh ¥35.01

## Monthly Cost



时间点	合计	尖	峰	平	谷
24:00	312.03 kWh ¥236.01	12.03 kWh ¥31.01	10.03 kWh ¥31.01	22.03 kWh ¥36.61	10.03 kWh ¥31.01
23:00	112.03 kWh ¥345.01	2.03 kWh ¥35.01	12.03 kWh ¥35.01	24.45 kWh ¥35.91	12.03 kWh ¥35.01
22:00	312.03 kWh ¥236.01	12.03 kWh ¥31.01	10.03 kWh ¥31.01	22.03 kWh ¥36.61	10.03 kWh ¥31.01
21:00	112.03 kWh ¥345.01	2.03 kWh ¥35.01	12.03 kWh ¥35.01	24.45 kWh ¥35.91	12.03 kWh ¥35.01

## Annual Cost

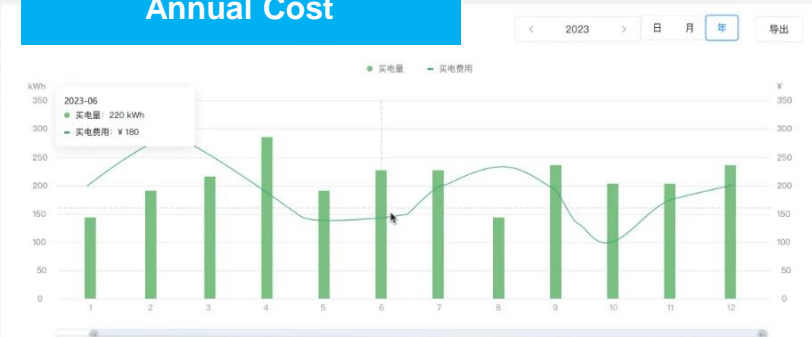

月份	合计	尖	峰			
2023-12	312.03 kWh ¥236.01	¥236.01	10.03 kWh ¥31.01	22.03 kWh ¥31.01	15.03 kWh ¥26.61	10.03 kWh ¥31.01
2023-11	112.03 kWh ¥345.01	¥345.01	12.03 kWh ¥35.01	24.45 kWh ¥35.01	16.03 kWh ¥31.91	12.03 kWh ¥35.01
2023-10	312.03 kWh ¥236.01	¥236.01	10.03 kWh ¥31.01	22.03 kWh ¥31.01	15.03 kWh ¥26.61	10.03 kWh ¥31.01
2023-09	112.03 kWh ¥345.01	¥345.01	12.03 kWh ¥35.01	24.45 kWh ¥35.01	16.03 kWh ¥31.91	12.03 kWh ¥35.01



# Alarm Management

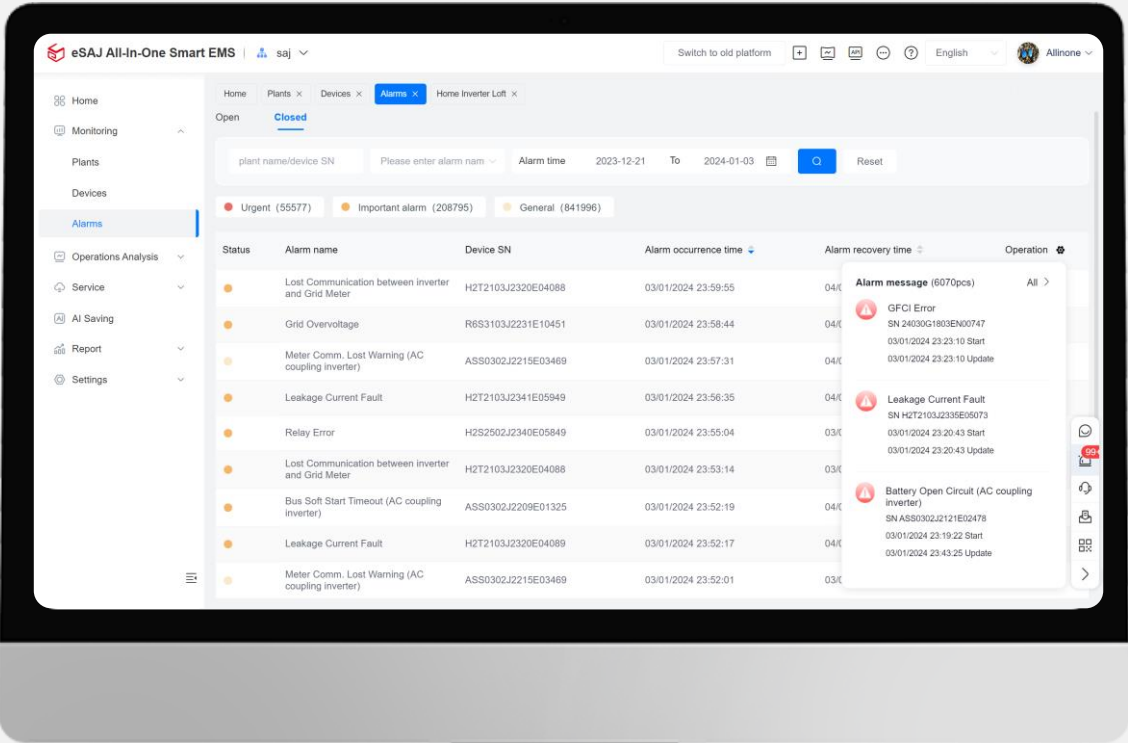

WEB

Alarm Statistics

Alarm Queries

Alarm Definitions

Alarm Categories

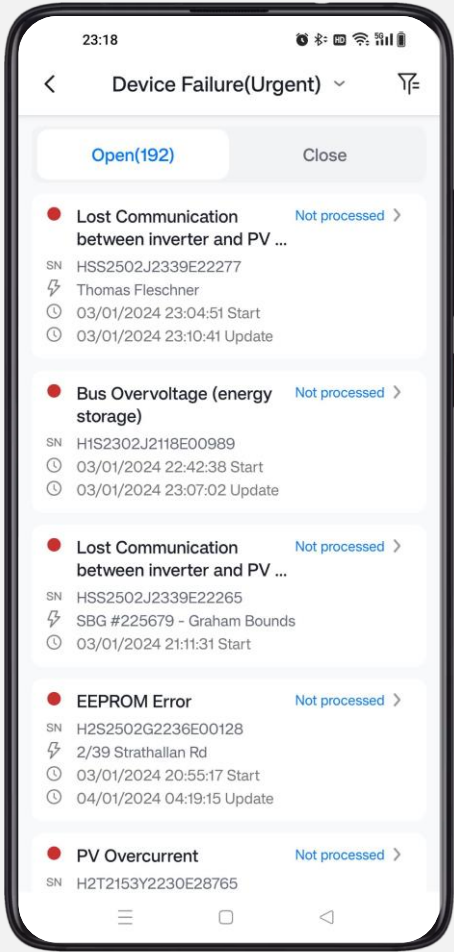

APP

## API

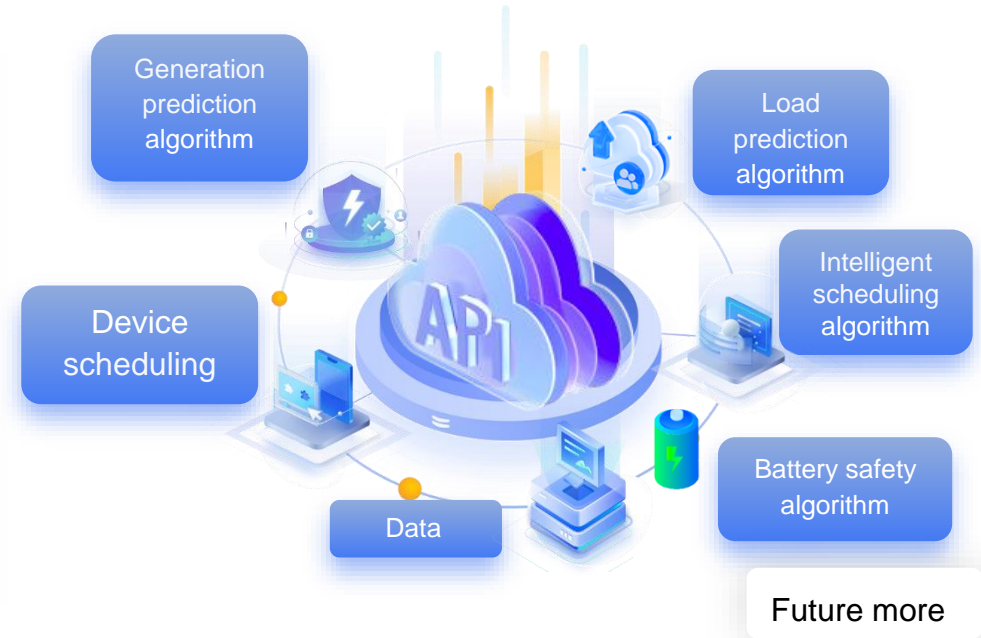
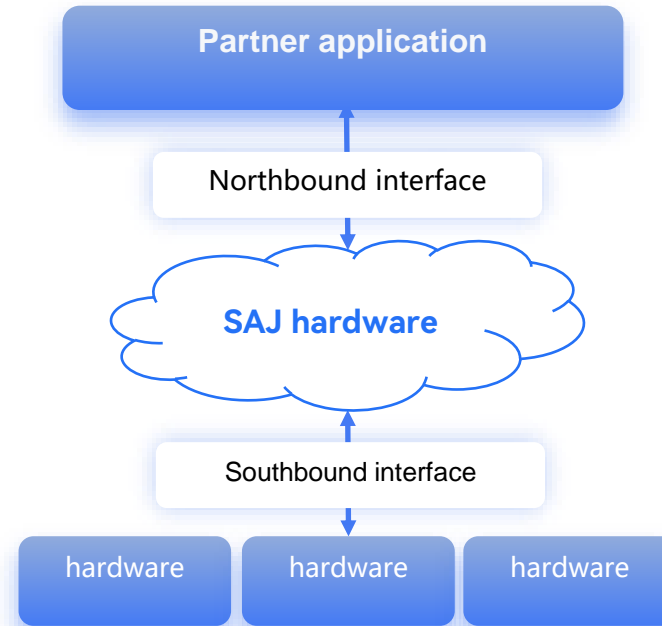

## Third-party energy operators:

It provides access and control interfaces for energy devices. Energy operators, developers can obtain the ability to interact with energy devices to achieve energy operation scenarios.

## Brand partner:

Provide the interface of eSAJ Home smart energy management system and other business systems, partners as developers can obtain the ability to interact with the business system, and realize their own more business.

**VPP:** Aggregate residential PV batteries for participation

**Energy Aggregators**



**Hardware solution**  
Local gateway of VPP

**SAJ**

- High stability
- Quick response



eSolar AIO3   eManager-C1 Pro   eManager

**Cloud to cloud solution**  
API

**SAJ Open Platform**

- Strong compatibility
- rapid iteration
- Lower costs



Approved







On Going

EPC/Installer





Aggregators

Grid Operators





## 01 Countries&Areas

Germany, Sweden, Finland, Norway, Spain, Portugal, Australia

## 02 Peak load shifting



## 03 Frequency regulation

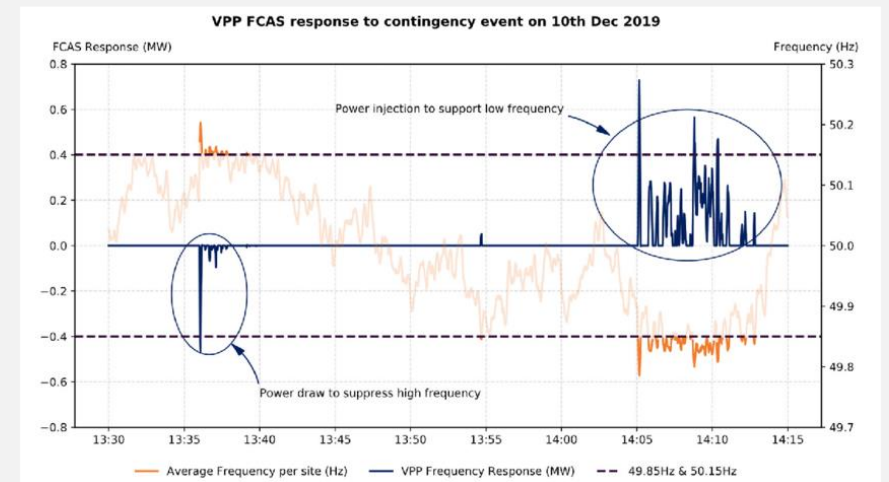



# THANK YOU

Revolutionize Energy Storage Solutions

**Guangzhou Sanjing Electric Co.,Ltd.**

Add: SAJ Innovation Park, No.9, Lizhishan Road, Science City, Guangzhou High-tech Zone, Guangdong, China.

E-mail: [marketing.drive@saj-electric.com](mailto:marketing.drive@saj-electric.com) Tel: +86 400-960-0112 Fax: +86 020-66608589 Web: [www.saj-electric.com](http://www.saj-electric.com)